

Precision packaging designed to deliver...

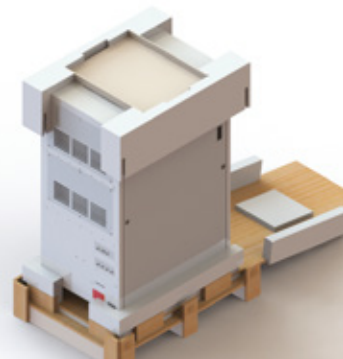

...value
protection
efficiency





Our business

At Macfarlane Packaging, we provide optimum protective packaging for high value products in transit and storage

When we design a protective packaging solution, it is created exclusively for your product. The risks are assessed, the supply chain costs are considered, and a design is proposed to meet all your criteria.

We use leading 3D design software, an extensive range of packaging materials and a variety of innovative techniques to:

- Deliver enhanced levels of protection, so you can ship your products with confidence
- Improve cost-efficiency, to help reduce your packaging and transport costs
- Eliminate excess packaging to reduce waste from your shipping operations
- Reduce assembly time and storage space
- Respect the environment by using recyclable and sustainable materials where possible.

**Design,
manufacture
and assembly
of bespoke
packaging**

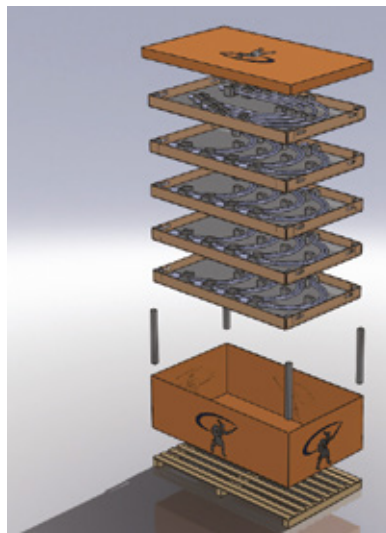

Macfarlane Manufacturing is a leading company in the design, manufacture and assembly of bespoke packaging for a range of industries.

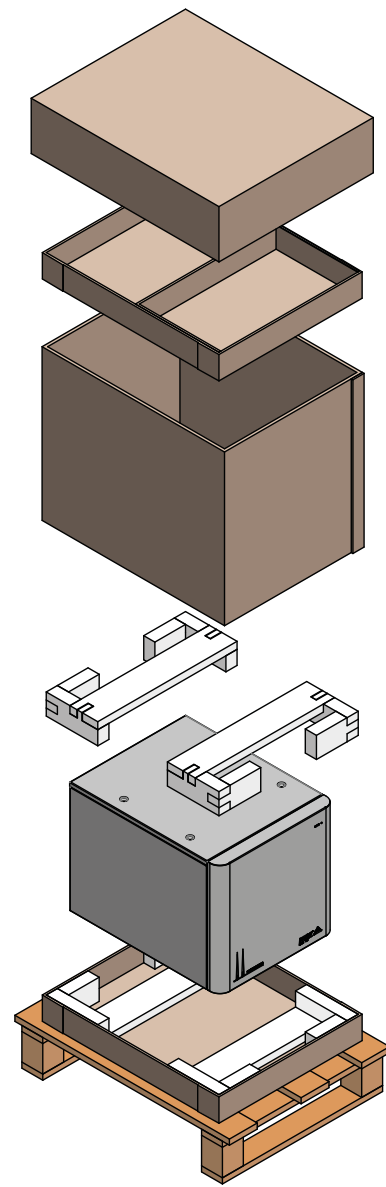

Design approach

The design approach is critical in producing bespoke packaging solutions. Our design approach follows four key stages:

- Develop a full understanding of the handling, storage and transportation conditions
- Assess the risks and protection requirements of the product
- Create an effective design using SolidWorks 3D CAD software
- Validate the design performance by testing under controlled conditions.



Solid Works

Macfarlane Packaging has invested in SolidWorks 3D CAD software, the same state-of-the-art design technology trusted by many of our customers in their own product development.

This makes it easy for both sets of designers to work together, exchange information, present and assess design proposals.

Through the use of further rendering and advanced 3D animation software, we can visualise the product at each stage of the design process.

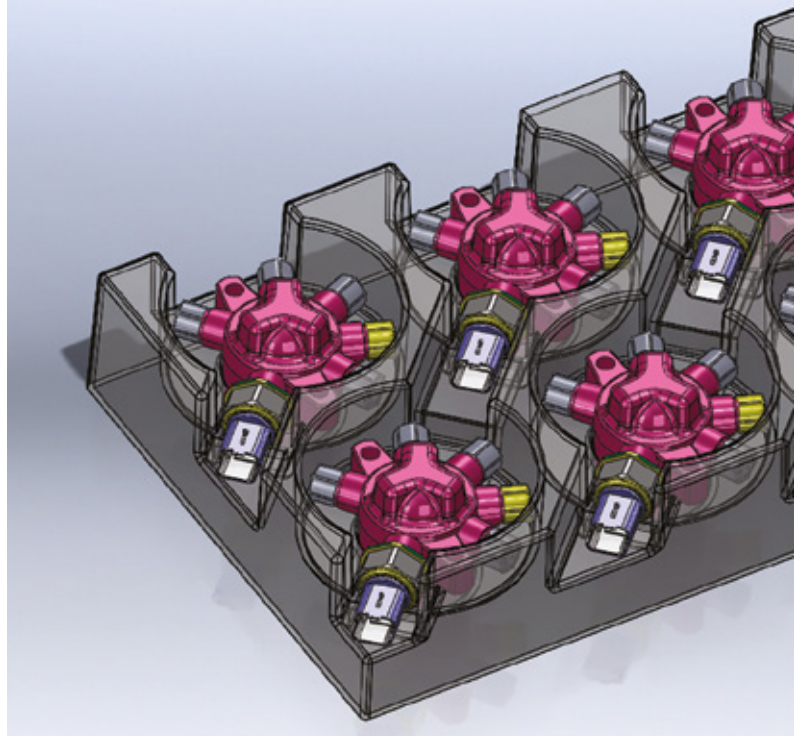

Materials

Designing packaging for efficient product protection depends upon choosing the right combination of materials. This not only eliminates the risk of damage, but helps deliver significant savings in shipping costs.

By working closely with leading manufacturers, we ensure that customers benefit from competitive prices across an unparalleled range of non-hazardous, recyclable and energy-efficient materials.

At the core of each successful application from Macfarlane are three key components:

- A thorough understanding of a wide range of materials and their capabilities
- The ability to combine materials in custom pack designs which offer superior levels of protection
- The resources to process all the component materials and assemble them into the finished packaging.



Industries

Aerospace

Our packaging for leading aerospace companies provides shock protection, electrostatic and magnetic protection and protection from extremes of temperature and humidity. Our designs also enable the handling of large components and allow for sub-contract packing.

Defence

All eventualities are covered, from basic commercial level packs – where items are to be shipped for immediate use – to situations where harsh transportation conditions and long-term storage are envisaged.

The level of packaging required is specified on the tender and contract documents by the MoD. Defence standards also cover the design and construction of the container.

Military Packer Accreditation Scheme

As an accredited MPAS (ex DR14) supplier, Macfarlane Packaging is authorised to formulate and sign off the SPIS documents on behalf of the MoD, which can be accredited to its comprehensive design, testing facilities and specially trained staff.

Electronics

Our packaging can protect vulnerable products from potentially catastrophic hazards. For example, specially treated materials can shield or dissipate the effects of ESD (electrostatic discharge) and a static-free production environment.

We can also advise about protection from the risk of a damaging charge or electrostatic spikes in packing and unpacking areas.



Industrial

Component suppliers subject to 'just in time' manufacturing pressures must ensure that goods arrive ready for immediate use.

Our cost-effective bespoke packaging prevents transit damage, protecting both assembly schedules and customer relations. Many suppliers also appreciate the economic and environmental benefits of re-usable packaging.

Medical

Equipment with magnetic and electrostatic sensitivity, lithium batteries, and radioactive components demand specialist measures.

Our design expertise ensures such products are safely transported, stored and delivered anywhere in the world.

Accreditation to ISO 9001:2008 – harmonised with ISO 13485 – underlines our commitment to continuous improvement.

Automotive

The challenges involved in protecting automotive components in transportation can be extremely complex.

We have considerable experience in providing bespoke packaging solutions that deliver increased levels of protection and reduce onward transport costs including:

- Line-ready packs
- Closed loop systems to provide ongoing service
- Rust and corrosion protection
- Ability to re-engineer existing packs with new internal fitments to allow for product evolution





Services

Our commitment to your business goes beyond design, manufacture and assembly. Our service proposition is equally tailored to your needs and includes:

- **Vendor managed inventory** – all the help you need in establishing and maintaining inventory for your packaging requirements
- **Customer Connect** – allows you to purchase online from an agreed bespoke product list. You see your purchasing history at a glance, with graphs, analyses, expenditure levels and a packaging waste report
- **Next day delivery** – through the Macfarlane network of regional centres, we can arrange for locally-held stocks available for rapid delivery. A brand new fleet of eco-friendly trucks delivers them to your door
- **Stock-holding and drip feed supply** – if you're short of storage space, we can warehouse your packaging goods in a clean, safe environment and deliver exactly what you need, precisely when required
- **Controlled packing service** – customers' parts packed on-site or off-site to defence standard.

Our ambition is to be your packaging supplier of choice, a trusted partner to ensure your valuable products are cost effectively protected in storage and transit.

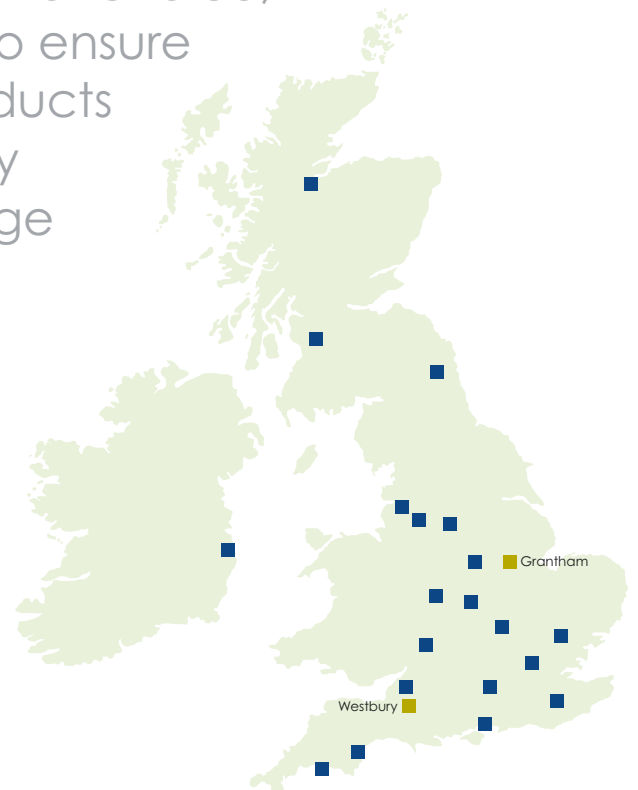

Macfarlane Packaging
Alma Park Industrial Estate
Grantham
Lincolnshire
NG31 9SE
T: 0844 770 1417
F: 0844 770 1418

Macfarlane Packaging
Quartermaster Road
West Wilts Trading Estate
Westbury
Wiltshire
BA13 4JT
T: 0844 770 1435
F: 0844 770 1436

T: 0844 770 1417
E: enquiries@macfarlanemanufacturing.com